

# Forestry crane

BK 4070 ECO

BK 7000 L

BK 7000 S

BK 8000

**Original Operator's Manual** Copyright by Binderberger GmbH



Read the operating instructions carefully before  
commissioning the machine!

**This manual is valid for:**

<b>Model</b>	<b>Article number</b>
Forestry crane BK 4070 ECO	FK-M70-3
Forestry crane BK 7000 L	FK-M70-1
Forestry crane BK 7000 S	FK-M70-2
Forestry crane BK 8000	FK-M80-1

**Version of this manual:** FK 3.1

**Creation date:** 2021-10

## Table of Content

1	EC Declaration of Conformity .....	5
2	Safety instructions .....	6
2.1	Explanation of symbols .....	6
2.2	Keep information available .....	7
2.3	General safety instructions .....	7
2.4	Operator requirements.....	7
2.5	Intended use .....	8
2.6	Misuse and residual risks .....	9
2.7	Modifications to the machine.....	9
3	Overview .....	10
3.1	How it works .....	10
3.2	Part description.....	11
3.3	Technical data .....	12
3.4	Lifting capacity .....	13
4	Transport of the machine .....	14
4.1	Safety instructions during transport.....	14
4.2	Transport journeys and journeys on public roads .....	14
5	Mounting and connecting.....	15
5.1	Safety instructions for assembly and connection.....	15
5.2	Duties before starting work.....	16
5.3	Important information! .....	16
5.4	Assembly of the crane .....	17
5.5	Connecting to the hydraulic system .....	18
5.6	Electrical supply line .....	19

- 6 Operation ..... 20
  - 6.1 Safety instructions during operation ..... 20
  - 6.2 Important notes during operation ..... 21
  - 6.3 Control before operation ..... 22
  - 6.4 Trial operation ..... 23
  - 6.5 Lever positions ..... 24
  - 6.6 Practising the lever positions ..... 27
  - 6.7 Working with the forestry crane ..... 28
  - 6.8 Working under special conditions ..... 29
  - 6.9 Daily Control ..... 29
- 7 Shutdown ..... 30
  - 7.1 Safety instructions for the shutdown procedure ..... 30
  - 7.2 Switch off the drive ..... 31
  - 7.3 Storing ..... 31
- 8 Maintenance ..... 32
  - 8.1 Safety instructions during maintenance ..... 32
  - 8.2 Notes when working on electrical equipment ..... 33
  - 8.3 Notes when working on hydraulic equipment ..... 33
  - 8.4 Cleaning ..... 33
  - 8.5 Lubrication ..... 34
  - 8.6 Changing the oil and filter on the auxiliary tank ..... 36
  - 8.7 Changing the hydraulic hoses ..... 36
  - 8.8 Maintenance and repair work ..... 39
  - 8.9 Duties before finishing maintenance ..... 40
- 9 Help in case of malfunctions ..... 41

9.1	Safety instructions .....	41
10	Guarantee and Warranty .....	44
11	Conduct when dealing with accidents .....	45
12	Behaviour in dangerous situations .....	46

## **1 EC Declaration of Conformity**

We hereby declare that the various technical versions of the machine:

Designation: \_\_\_\_\_  
Type: BK forestry crane  
Serial number: \_\_\_\_\_

comply with the provisions of the Machinery Directive 2006/42 / EC and the other related standards.

The machine mentioned meets the requirements of the EMC Directive 2004/108 / EC and the Low Voltage Directive 2006/95 / EC.

The accompanying safety regulations and operating instructions apply to these machines.

The machines must not be modified. If changes are made to the machine that have not been agreed with us, this declaration becomes invalid.

The following named place

- has carried out the type examination. The product has received the EC type examination under the number \_\_\_\_\_.
- has carried out the EC type-examination procedure specified in Annex IX of 2006/42 / EC.

\_\_\_\_\_  
*Notified checkplace for type examination according to Annex IX*

The following is the name and address of the person authorized to compile the technical documentation.

CEO Karl Binderberger  
Binderberger Maschinenbau GmbH  
Fillmannsbach 9  
AT-5144 St. Georgen am Fillmannsbach

## 2 Safety instructions

### 2.1 Explanation of symbols

Please pay attention to the meaning of the following symbolic explanations and instructions description. They are divided into levels of risk and classified in accordance with ISO 3864- 2

<b>DANGER</b>	
	<p><i>Indicates an immediate threat of danger. If the information is not followed, death or serious bodily injury (invalidity) is the result.</i></p>

<b>WARNING</b>	
	<p><i>Indicates a potentially dangerous situation. If the information is not followed, death or serious bodily injury (disability) are the result</i></p>

<b>CAUTION</b>	
	<p><i>Indicates a potentially dangerous situation. If the information is not followed, material damage as well as minor or moderate physical injuries are the result.</i></p>

<b>NOTICE</b>	
	<p><i>Indicates general instructions, useful operator instructions and working recommendations that have no influence on the safety and health of personnel.</i></p>

## 2.2 Keep information available

These operating instructions must be kept with the machine. It must be ensured that all persons who have to carry out activities on the machine can read the operating instructions at any time.

All safety instruction signs and operating instruction signs on the machine must always be kept in a clearly legible condition. Damaged or illegible signs must be replaced immediately.

## 2.3 General safety instructions

The machine may only be operated by people who are trained, instructed and authorised for its use. These people must know the operating instructions and act in accordance with them. The respective competences of the operating personnel are clearly defined.

Operating personnel undergoing training may only initially work with the machine under the supervision of an experienced person. The completed and successful instruction is to be confirmed in writing.

## 2.4 Operator requirements

No special knowledge of mechanical or electrical engineering is required to operate the machine. However, the operator must be at least **18 years** old. The operator must be trained and instructed accordingly by the operator of the machine before starting work for the first time. Protective footwear and close-fitting clothing must be worn when operating the machines.

If the operator carries out maintenance and servicing work, he must have the necessary specialist knowledge.



## 2.5 Intended use

The forestry cranes are designed exclusively for forestry use for lifting and transporting goods. Any other use is not in accordance with the intended use. The operator of the machine, not the manufacturer, is responsible for any personal injury or damage to property resulting from improper use!

Intended use also includes reading these operating instructions and complying with all the information contained in them, especially the safety instructions. It also includes that all inspection and maintenance work is carried out at the prescribed intervals.

The crane can be operated with different load handling attachments. Only products approved by Binderberger GmbH count as valid load handling attachments.

**Attention:**

The use of load handling attachments other than timber grabs, as indicated in the intended use, may require additional safety devices such as load holding valves.

## 2.6 Misuse and residual risks

Despite correct application of all safety instructions for the machine, residual risks can still occur. These usually result from misuse of the machine.

- Touching rotating or moving components
- Injury from falling wooden or machine parts.
- Fire hazard due to inadequate ventilation of the engine
- Hearing damage from working without hearing protection
- Human error:
  - Mental overload
  - Entering a danger zone
  - Distractions
  - Neglected control activities

## 2.7 Modifications to the machine

For safety reasons, no unauthorised modifications may be made to the machine; this applies in particular to welding work on load-bearing parts.

Only use original spare parts / original wear parts / original accessories - these parts are specially designed for the machine. In the case of externally sourced parts, there is no guarantee that they are designed and manufactured to withstand stress and safety.

Parts and special equipment not supplied by us are also not approved by us for use on the machine.

## **3 Overview**

### **3.1 How it works**

The Binderberger forestry crane (FK) is a machine that can be mounted on a tractor or a timber trailer. The device is hydraulically operated. The supply is either via the tractor or via a self-supply.

Various functions can be implemented with the control system, the control valve.

- slewing gear
- Lifting arm up / down
- Articulated arm up / down
- Extend / retract extension arm (depending on model)
- Rotate rotator
- Gripper open / close
- Supports up / down

### 3.2 Part description

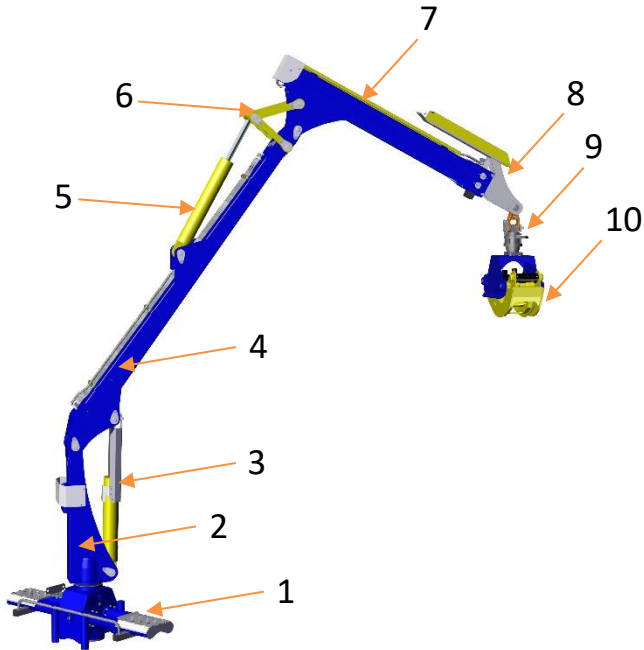

Number	Description
1	Slewing mechanism
2	Column
3	Inner boom cylinder
4	Inner boom
5	Outer boom cylinder
6	Knee lever
7	Outer boom
8	Telescope
9	Rotator
10	Gripper

### 3.3 Technical data

	<b>BK 4070 ECO</b>	<b>BK 7000 L</b>	<b>BK 7000 S</b>	<b>BK 8000</b>
Maximum range	7,0 m	7,0 m	7,0 m	8,0 m
Working pressure	180 bar	190 bar	210 bar	210 bar
Angle of rotation	360°	370°	370°	370°
Telescope	1,40 m	1,40 m	1,40 m	2,00 m
Rotating cylinder	4 St.	4 St.	4 St.	4 St.
Crane torque	14,5 kNm	22 kNm	22 kNm	22 kNm
Lifting force	7,0 m – 580 kg	7,0 m – 820 kg	7,0 m – 940 kg	8,0 m – 720 kg
Curb weight	745 kg	1200 kg	1200 kg	1280 kg
Support legs	hydraulic	hydraulic	hydraulic	hydraulic

### 3.4 Lifting capacity

The table below indicates the lifting capacity of the crane at the grapples, i.e. with the rotator and grapple not mounted.

Crane lift	<b>BK 4070 ECO</b>	<b>BK 7000 L</b>	<b>BK 7000 S</b>	<b>BK 8000</b>
3 m	k.A.	1950 kg	2200 kg	1950 kg
4 m	1000 kg	1400 kg	1500 kg	1450 kg
5 m	k.A.	1150 kg	1330 kg	1150 kg
6 m	k.A.	950 kg	1000 kg	950 kg
7 m	580 kg	820 kg	940 kg	820 kg
8 m	-	-	-	720 kg

## 4 Transport of the machine

### 4.1 Safety instructions during transport

<h1>WARNING</h1>	
	<p style="text-align: center;"><u><b>Risk of injury during transport!</b></u></p> <ul style="list-style-type: none"><li>• Make sure that there are no persons in the danger zone and that a sufficient safety distance is kept!</li><li>• Lubricants may have leaked out due to inclined positions during transport, there is a risk of chemical burns in case of direct contact with the skin!</li><li>• Do not stand under suspended loads, they may fall down!</li><li>• The machine may only be lifted at the intended holding points!</li></ul>

### 4.2 Transport journeys and journeys on public roads

When driving on public roads, the legal regulations must be observed!

- Keep reflectors and lamps clean.
- While driving, the grapple must not hang freely in the air, but must be supported on the trolley or the load.
- When driving the vehicle, the driving speed must be adapted to the ground conditions. In this way you protect the forestry crane from strong vibrations which have an unfavourable effect on the connections.
- Be aware of reduced steerability due to the heavy weight of the loaded vehicle.
- Pay attention to the total height when passing under bridges.

## 5 Mounting and connecting

### 5.1 Safety instructions for assembly and connection

<h1>WARNING</h1>	
	<p><b><u>Risk of injury if the machine is not set up correctly!</u></b></p> <ul style="list-style-type: none"><li>• Always check the machine for transport damage before setting it up!</li><li>• Set up the machine on a level and firm surface!</li><li>• If available, use the machine's support feet!</li><li>• Ensure that no persons are endangered by the installation!</li><li>• Lay machine connections, cables and hoses in such a way that there are no tripping hazards!</li><li>• The machine may only be operated when in perfect condition!</li><li>• Do not connect or disconnect pressurised hoses!</li><li>• Hoses under pressure must not be routed into the operator's cab! If this is not possible, it must be ensured that the operator cannot be injured if the hose bursts!</li></ul>



## 5.2 Duties before starting work

<h1>NOTICE</h1>	
	<p><b><u>Carry out the following activities before starting work:</u></b></p> <ul style="list-style-type: none"><li>• Assembly and connection must be carried out according to instructions.</li><li>• Check all hoses, couplings, bolts and screw connections for tightness before starting work.</li><li>• At outdoor temperatures below 0° Celsius, let the machine run for approx. 10 minutes at idle speed without load.</li></ul>

## 5.3 Important information!

**Read carefully before commissioning!**

Please note that the return hose of the control block (for machines without their own oil supply) must always be connected to a **pressure-free return**.

Likewise, please note that the return line must always be connected first and then the pressure hose!

Connection to a double-acting control unit is never pressure-free and can cause damage to the control block.

Please also ensure that no function is ever actuated on the control block (even unintentionally) until at least the return line is connected to the tractor. This can also lead to considerable damage to the control block.

## 5.4 Assembly of the crane

- For use on the tractor's three-point linkage, the crane can be mounted on a 3-point stand.
- The crane can also be mounted on the rear axle of the tractor using brand-specific mounting material.
- This should be carried out by the tractor manufacturer or by an authorised workshop of the manufacturer.
- The assembler must have sufficient experience in installing cranes.
- When operating in the forest, the crane should be mounted on a rear carriage for smoother and safer driving.

## 5.5 Connecting to the hydraulic system

Before connecting the crane to the tractor's hydraulic system, ensure that the oil types are miscible. The crane has undergone a test run with HVI 46 hydraulic oil. This is an oil intended for hydraulic systems that are used under highly fluctuating temperatures. The crane already has one oil filling on delivery.

### **Connection:**

The most advantageous connection method is to connect the pressure hose to a single-acting connection on the hydraulic system, with the return line going directly to the tank via a filter. The crane can also be connected to a double-acting hydraulic connection. In this case, the pressure hoses are each connected to their own connection.

In this case, note in which direction the double-acting valves must be set. The pressure goes to the pressure connection of the crane's control valve. Refer to the operating instructions of the power unit to find out how the double-acting connections work. Make sure that all quick couplings are securely coupled.

**Make sure that no pressure is applied to the return line of the control valve. The valve can be damaged in this case and the crane cannot be operated.**

Ensure permanent cleanliness in all hydraulic installations!

Check that pressure is applied to the correct hose by operating a function.

### **Attention!**

**The crane must not be loaded or moved to the end position during this test.**

Play through all movements and check that all hoses can move freely and are not stretched too much.

**Protection of the hoses:**

The hoses must be placed in such a way that they are protected and cannot be damaged by chafing, twisting or pinching. If for any reason the pressure hoses have to be routed through the operator's cab, it is essential that they are shielded so that if a hose bursts, the operator is not hit by the oil and injured.

**Connection to a closed system or load-sensing system:**

Installation instructions and a list of components are available from the manufacturer's authorised dealer.

## **5.6 Electrical supply line**

Only use the cables supplied with the forestry crane.  
The 3 or 7-pin plug must be connected to the tractor.

**Never carry out work on electrical equipment if you do not have the necessary expertise!**

## 6 Operation

### 6.1 Safety instructions during operation

<b>DANGER</b>	
	<p><b><u>Risk of injury from being caught or pulled in on moving machine parts!</u></b></p> <ul style="list-style-type: none"><li>• Keep a sufficient safety distance from moving machine parts!</li><li>• Do not stand under suspended loads, they can fall down!</li></ul>

<b>WARNING</b>	
	<p><b><u>Risk of injury when operating!</u></b></p> <ul style="list-style-type: none"><li>• Make sure that there are no persons in the danger zone and that a sufficient safety distance is kept! (min. 25 metres)</li><li>• Familiarise yourself with the operating elements of the forestry crane!</li><li>• Ensure that the machine is in a safe position!</li><li>• The parking brake of the tractor must be activated!</li><li>• Permissible loads must not be exceeded.</li><li>• Never transport persons.</li><li>• Use a standardised forestry helmet or similar head protection when working with the crane!</li><li>• All parts that do not belong to the machine must be removed from its environment.</li></ul>

## 6.2 Important notes during operation

<h1>NOTICE</h1>	
	<ul style="list-style-type: none"><li>• The operating personnel must ensure that no unauthorised persons are in the working area of the machine.</li><li>• Before switching on the machine, inform yourself about the correct behaviour in case of malfunctions.</li><li>• Before switching on the machine, carry out the points listed in chapter "Check before trial operation".</li><li>• After switching off the machine, always carry out the work steps in the following chapter "Decommissioning".</li><li>• If the operator leaves the machine unattended, it must be shut down and secured against unauthorised restarting.</li><li>• Wear protective gloves and safety shoes with steel toecaps.</li></ul>

### Operation under power lines:

Pay strict attention to the safety distance when working under power lines. No part of the appliance may be closer to power lines than the safety distances given below:

Low-voltage power lines: min. 2 metres  
High-voltage power lines: min. 6 metres

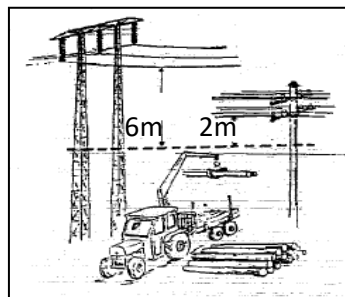

### 6.3 Control before operation

- The person carrying out the test operation should have relevant experience with cranes.
- The unit should stand on level ground. Avoid loading operations when the vehicle is on sloping ground.
- During loading, the parking brakes of the tractor must always be applied. If necessary, place brake pads in front of the wheels.
- The crane support feet must be extended each time the crane is used. When doing so, ensure that the ground is firm and does not give way.
- Check the oil level in the hydraulic system.
- Make sure that the hoses can move freely.
- Check the crane for damage, cracks, leaks and in test run for proper functioning.
- Make sure that there are no unauthorised persons in the working area of 25 metres.
- Make sure that there are no obstacles (cables, power poles, etc.) within the operating range.
- Make sure that all control levers are in the zero position before activating the machine.

## 6.4 Trial operation

At the beginning of each work, the crane must be tried out at a low power level. When all functions of the crane are performed, the handling of the functions is practised or the memory is refreshed.

In addition, this tests the crane's functionality and allows the oil in the hydraulic system to circulate and slowly come up to operating temperature.

It is recommended that only one function of the crane is operated at a time during the test run. Once the worker is trained and experienced, several movements can be performed at the same time.

Move all cylinders **CAREFULLY** to the end positions regarding bleeding of the cylinders. If there is air in the cylinders, this can cause the crane to make sudden, erratic movements. It may happen that a movement continues even after the valve has been switched off.

**Exercise caution!**



## 6.5 Lever positions

There are different control valves depending on the crane type. Each function must be tested before starting work. Perform lever movements softly and smoothly, without fast or jerky movements. If you avoid sudden movements, you will increase work safety and prevent unnecessary repairs. Note that if several functions are used at the same time, the oil flow is divided between the respective cylinders, slowing down the movements.

The following illustrations show the different functions of the crane.

**1. Joysticksteuerung**

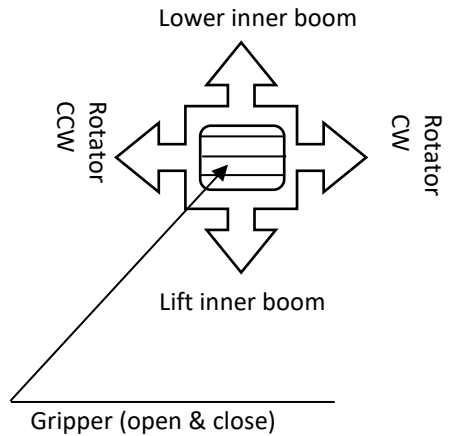
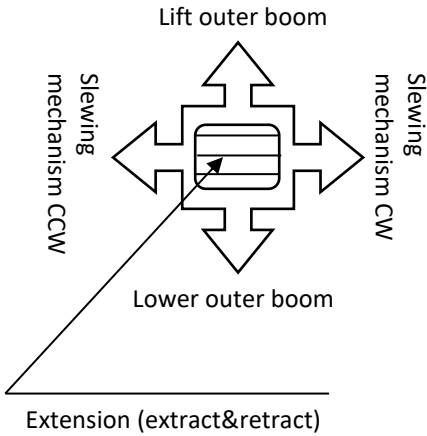

Dead man's button  
 (Required for crane supports and additional function)

Crane supports up/down

Additional function  
 (Depending on the respective equipment)



**2. Two level control valve with push button**

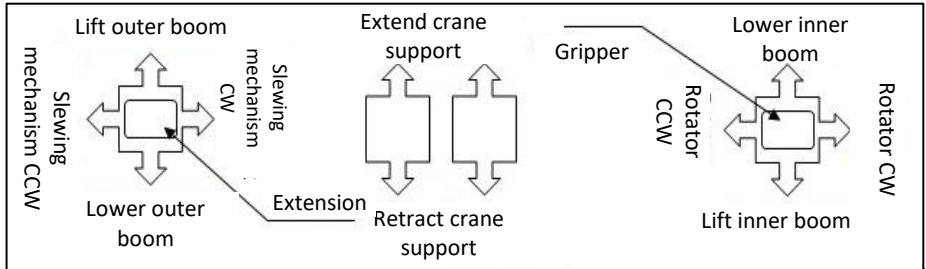

**3. Two lever control valve rotatable**

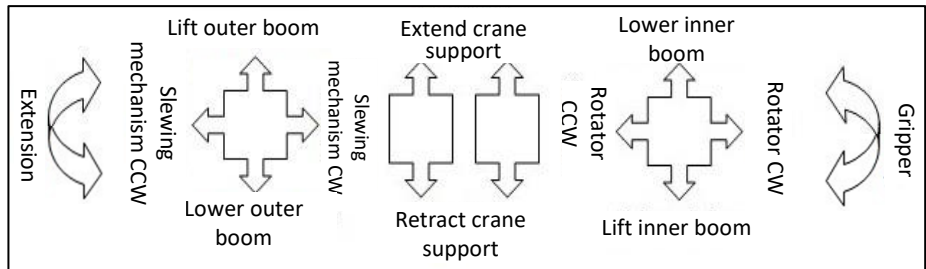

## 6.6 Practising the lever positions

To begin with, practise with the tractor at a low power level. With your left hand you operate the slewing gear and the cylinder of the outer boom, with your right hand you control the rotator and the inner boom. Depending on the valve variant, the functions of the grab and the extension are added. An experienced crane operator works with several functions simultaneously.

- Get used to the function of the control valves. Go through all movement paths in unloaded condition. Make it a habit to avoid those positions where the crane risks hitting the tractor's operator's cab or otherwise colliding with it.
- Get used to operating several functions at the same time. This enables a smooth and precise movement, which reduces the wear and tear on the crane. However, as the oil flow is distributed to several cylinders at the same time, the movements slow down.
- Perform the lever operation softly and smoothly, without fast or jerky movements. If you avoid sudden movements, you will increase work safety and avoid unnecessary repairs.
- When practising, it is advisable to operate the pump at a lower power level, as this prevents jerky movements.
- When you have become accustomed to the crane's movements, you can select a suitable power level to work effectively. However, this should only be done when you have mastered the movements.

## 6.7 Working with the forestry crane

If possible, loading work should be carried out so that the crane extension is retracted. When the boom is in the outermost position, do not use it to lift heavy loads. In any case, observe the lifting capacity table and do not try to push the crane to its performance limits.

In consideration of the crane's service life and for safety reasons, it is recommended that the load is lifted by retracting the extension.

Do not activate the crane's rotation until the load is fully in the air.

Avoid loading on slopes. If you nevertheless have to work on sloping ground, be especially careful. In this case, the crane should also not be used with maximum lifting moment. If you are working on a slope and the load is downhill from the crane, be aware that the force of the rotation may not be sufficient to hold the load in position. The pressure relief valves may be overloaded and the load may become self-supporting downhill, taking the whole crane with it.

Avoid driving the crane at full speed to the end position of the movement paths. Do not exceed the permissible load values. If the load to be moved is close to the maximum load, extra care must be taken. Please refer to the information on the maximum load for the respective crane in the section "Lifting capacity table".

Never extend the slewing gear at high speed towards the end position! You risk tipping over the load and damaging the jib bearing.

Please remember to take special care near electrical equipment. Observe the safety distance.

## 6.8 Working under special conditions

The lowest recommended working temperature of the forestry crane is -25°C.

It should be noted that the hydraulic seals wear out faster at low temperatures and the hoses become more susceptible to damage. In addition, the likelihood of cracks forming in the steel structure due to cold-induced brittleness increases.

- Before starting work at low temperatures, allow the oil to circulate freely for around 5 minutes.
- Play through all function's forwards and backwards so that the seals become supple.
- Only then increase the load.

In very hot climatic conditions, make sure that the oil does not overheat. An excessively high oil temperature (> 80°C) reduces the service life of the oil and damages the seals.

## 6.9 Daily Control

Visually inspect the unit. Look for faults and defects that could have an influence on safety. Any faults and defects must be rectified.

- Make sure that there are no leaks in the hydraulics.
- Make sure that there are no damaged hoses.
- Check the bolts and nuts on the boom parts, the attachment to the grapple, the mounting of the crane on the mounting block and the cylinder brackets. Lubricate the unit if necessary. Test all functions of the crane by moving them once to the end position.

## 7 Shutdown

### 7.1 Safety instructions for the shutdown procedure

<b>DANGER</b>	
	<p><b><u>Risk of injury from being caught or pulled in on moving machine parts!</u></b></p> <ul style="list-style-type: none"><li>• After parking, wait until all moving machine parts have come to a standstill!</li><li>• Keep a sufficient safety distance from moving machine parts!</li></ul>

<b>WARNING</b>	
	<p><b><u>Risk of injury when taking out of operation!</u></b></p> <ul style="list-style-type: none"><li>• Make sure that there are no persons in the danger zone and that a sufficient safety distance is kept!</li><li>• Do not stand under suspended loads, they may fall down!</li><li>• Ensure that there are no persons between the machine and the tractor!</li><li>• Secure the machine after operation against unauthorised switching on!</li></ul>

## 7.2 Switch off the drive

### Uncoupling from the tractor:

- Switch off the tractor.
- Depressurise all hydraulic functions of the machine. To do this, move all control levers to the home position.
- Now the hoses can be disconnected from the tractor.

### Uncoupling from the timber trailer:

- Switch off the tractor's PTO shaft and secure it against being switched on again.
- Depressurise all hydraulic functions of the machine. To do this, move all control levers to the home position.
- Disconnect the PTO shaft from the tractor.

## 7.3 Storing

- Proper parking of the crane when not in use promotes operational safety and resale value.
- The crane should be cleaned and paint damage spot repaired before the machine is parked.
- All lubrication points should be lubricated.
- Apply a thin layer of lubricant to areas that cannot be spot painted or lubricated.
- Carefully clean and dry the hoses.
- Lower the pressure in the cylinders.
- The parking place should be cool and dry.



## 8 Maintenance

### 8.1 Safety instructions during maintenance

<b>DANGER</b>	
	<p><b><u>Risk of severe injury by switching on the driving mechanism during maintenance work!</u></b></p> <ul style="list-style-type: none"><li>• Switch off machine!</li><li>• Secure against unintentional restart!</li></ul>

<b>CAUTION</b>	
	<p><b><u>Risk of injury! Scalding by hot machine components and media!</u></b></p> <ul style="list-style-type: none"><li>• Allow the machine to cool down to ambient temperature before carrying out any maintenance work.</li><li>• Keep highly flammable material away from hot surfaces.</li></ul>

<b>CAUTION</b>	
	<p><b><u>Risk of chemical burns from contact with lubricants!</u></b></p> <ul style="list-style-type: none"><li>• Avoid skin and eye contact.</li><li>• Do not swallow or inhale.</li><li>• Use appropriate protective equipment (gloves, goggles).</li><li>• Use suitable collection containers.</li><li>• Remove spilled oil immediately</li></ul>

## 8.2 Notes when working on electrical equipment

All work on the electrical equipment of the machine may only be carried out by trained electricians.

- Check electrical equipment regularly.
- Reattach loose connections.
- Replace damaged lines or cables immediately.
- Never clean electrical equipment with water or similar liquids.

## 8.3 Notes when working on hydraulic equipment

All work on the machine's hydraulic equipment may only be carried out by trained specialists.

- Depressurise all hydraulic systems / system parts before starting work.
- Before starting work, ensure that suitable collection containers are available for all substances hazardous to groundwater (oils, coolants, etc.).

## 8.4 Cleaning

After each operation and before each maintenance, the machine must be cleaned of dirt!

After each cleaning with water, the crane must be lubricated!

## 8.5 Lubrication

Lubrication should be carried out according to the scheme shown below. It is more expedient to lubricate more often instead of using a lot of lubricant at once. Damaged grease nipples should be replaced.

Use only branded grease. Do not use greases with solid additives, such as molybdenum sulphide (MoS<sub>2</sub>). This can lead to accelerated bearing wear.

### Warning.

If, for example, the lubrication channel of an axle journal or bearing housing becomes clogged and the grease therefore cannot penetrate, stop operation and clean the lubrication channel.

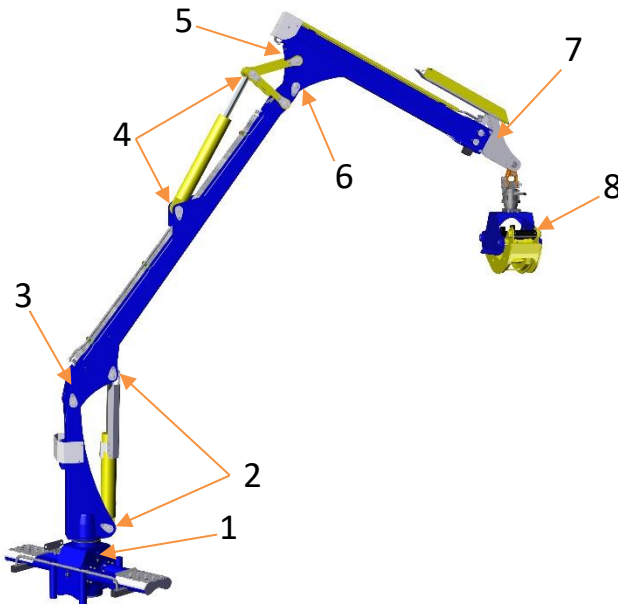

Pos	Lubrication point	BK 4070 ECO	BK 7000 L BK 7000 S	BK 8000	Interval
1	Slewing gear upper bearing	2x			8 h
2	Joints of the lifting cylinder	2x			
3	Bearing between column and main boom	1x			
4	Joint of articulated arm cylinder	2x			
5	Knee lever joints	5x	4x	4x	
6	Extension cylinder				
7	The extension boom should be regularly greased lightly with a brush.	x			
8	Rotator joint	2x			
9	Gripper	10x			
	Checking the oil level of the slewing gear	x			50 h
	Oil in the gearbox of the slewing gear	Gear oil SAE 80/90			250 h or at least once per year

## **8.6 Changing the oil and filter on the auxiliary tank** (only for self-supply)

The first oil change must be carried out after 50 operating hours. Thereafter, the oil should be changed every 250 operating hours or at least once a year.

Use HVI 46, or equivalent hydraulic oil.

Always renew the oil filter together with the oil change.

## **8.7 Changing the hydraulic hoses**

All hydraulic hoses must be replaced after 5 years.

Otherwise, damage to the hoses can cause serious injuries.

Maintenance object	Measures	
	Maintenance interval Operating hours	
	In the first 10h / thereafter every 25h	Every 250 h
General	All bolts and nuts must be tight. <b>Especially important with new cranes!</b>	
	Check whether axles are free of play	
	Check that all axles are tight	
	Check fuses and guides	
	Check cylinders, hoses and couplings for leaks. Replace if damaged!	
	Check for cracks in the material or defects in the construction!	
Slewing gear	Retighten the fastening bolts	Checking the side bearings, side play
	Check the support bearings of the gear racks	
Cylinder		Checking the controls and bearings of the hydraulic cylinders
Extension		Check the plain bearing play
Tools		Fastening the tool to the rotator
Support, mounting trestle		Checking the controls and bearings of the hydraulic cylinders
Pendulum brake (optional)		Check the friction lining

**Descent rate for the boom system:**

The rate of descent measured at the tip of the boom system caused by leakage within the hydraulic components must not exceed 5% of the outreach per minute.

The rate of descent must be tested at maximum load capacity and at maximum hydraulic outreach.

Determine the wear of the bearings:

Measure the distance X between the crane column and the surface of the slewing gear housing when the crane is raised. Note the value.

Lower the crane onto a support and press down with appropriate force.

Measure again the point X described above.

The difference between the two values must not exceed 2.6 mm.

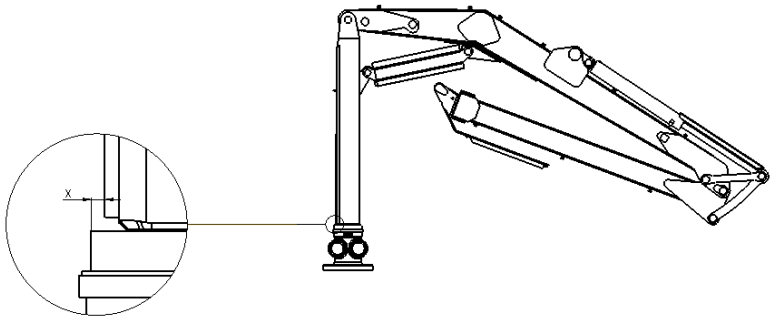

## 8.8 Maintenance and repair work

**Remember: Defects discovered early can prevent accidents. Pay attention to the greatest possible cleanliness so that the hydraulic system is not damaged.**

**Spare parts can be obtained from your authorised dealer or Binderberger.**

### Adjusting the extension play:

- Check the extension for the first time after 25 operating hours and then every 250 operating hours.
- If you notice play between the extension and the articulated boom, readjust the plastic sliding jaws using the adjusting screw.
- Remove the locking screw and turn the adjusting nuts a quarter turn further.
- Turn the left and right adjustment nuts equally.
- Do not tighten the sliding jaws too much so that the extension does not become sluggish.
- Refit the locking screw.
- Grease the sliding surfaces with a brush if necessary.

**If you do not have the technical knowledge, consult a specialist workshop!**



Adjusting the pendulum brake of the rotator joint: optional

- Check the pendulum brake for the first time after 25 operating hours and then every 250 operating hours.
- Swing the boom sideways so that the grapple swings over the entire movement path.
- If the grapple swings back and forth more than twice before stopping, the pendulum brake must be readjusted.
- Adjustment is made by turning the brake block adjustment screw.
- If the thickness of the brake pad friction lining is less than 2 mm, the brake pad must be replaced.
- Make sure that no grease gets on the friction lining.

## 8.9 Duties before finishing maintenance

After completing the maintenance work and before starting the machine, observe the following points:

- Check all previously loosened screw connections for tightness.
- Check that all previously removed guards, covers, container lids, .... are properly reinstalled.
- Make sure that all tools, materials and other equipment used have been removed from the work area.
- Clean the work area and remove any spilled liquids and similar substances.
- Ensure that all safety devices of the machine are working properly again.
- Check the operation of the safety devices. Do not release the machine for use if the safety devices are not functioning properly.
- Carry out a test run with a function check of the repaired components.
- Secure the machine against unauthorised switching on if you have not completed the work.
- Do not handle naked flames or smoke.

## 9 Help in case of malfunctions

### 9.1 Safety instructions

<b>DANGER</b>	
	<p><b><u>Serious risk of injury from switching on the drive in the event of a malfunction!</u></b></p> <ul style="list-style-type: none"><li>• Switch off the machine!</li><li>• Secure against being switched on again!</li></ul>

<b>CAUTION</b>	
	<p><b><u>Risk of injury! Scalding by hot machine components and media!</u></b></p> <ul style="list-style-type: none"><li>• Allow the machine to cool down to ambient temperature before carrying out any troubleshooting.</li></ul>

<b>CAUTION</b>	
	<p><b><u>Risk of chemical burns from contact with lubricants!</u></b></p> <ul style="list-style-type: none"><li>• Avoid skin and eye contact.</li><li>• Do not swallow or inhale.</li><li>• Use suitable protective equipment (gloves, goggles).</li></ul>

<b>Error</b>	<b>Cause</b>	<b>Error correction</b>
Working movements of the crane are slow	The pump of the crane works too slow	Check the revolutions of the pump
	Too little oil	Top up oil (bleeding)
	Pump damaged	Repair or replace pump
	Leakage or disconnection of an oil line	Check oil lines
	Oil too thick	Use a thinner oil (correct viscosity)
	Simultaneous operation of several cylinders	Operate fewer cylinders at the same time
Lowering movements of the crane are slow	Oil hoses disconnected	Check the hoses and the protective coils for the hose lines
	Oil too thick	Use a thinner oil (correct viscosity)
	If present: Hose rupture protection defective	Replace hose rupture protection
Crane movements are too fast	Rpm too high / Pump too large	Select the correct number of revolutions and pump
	Wrong operating mode	Operate the levers more gently and carefully
The lifting cylinder sinks by itself	Fault in the Control valve	Have the control valve repaired or replaced
	Fault in the cylinders or hoses	Check cylinder and replace hoses

Crane movements are powerless	Too little oil	Top up oil (bleeding)
	Pump damaged	Have the pump repaired or replaced
	Pressure relief valve or secondary relief valve damaged	Replace pressure relief valve or secondary relief valve
	Fault on the control valve	Have control valve repaired or replaced
	Fault on the cylinders or seals	Check cylinders and replace seals
Crane moves jerkily	Air in the hydraulic system	Make sure there is enough oil in the tank
		Make sure there are no pinch-offs or leaks on the suction side
	Pump damaged	Have the pump repaired or replaced
One control piston of the valve is stuck	Valve tightening screws too tight	Check the tightening torque of the screws: 50Nm
	The valve is not lying on a flat surface	Make sure that the mounting base is level
	The pull rod of the valve is too tight	Check the tightening torque of the tie rod: Ex 38 control: 40 Nm HCD control: 35 Nm
<b>If the malfunctions cannot be eliminated according to the above instructions. Please contact your dealer! He will be happy to help you.</b>		

## **10 Guarantee and Warranty**

A guarantee period of 12 months and a warranty period of 24 months from the date of invoice is granted for the firewood processor (please keep the invoice!).

The warranty claim covers all material and / or manufacturing defects.

Defective parts will be replaced free of charge - they may only be replaced by a specialist. Please request and replace damaged stickers.

No warranty is given for:

- Damage caused by improper handling or use.
- Transport damage - this must be reported to the delivery company immediately after receipt of the goods delivery.
- Modifications or changes to the machine or if no original spare parts or standard parts were used for repair work.

## **11 Conduct when dealing with accidents**

As a matter of routine, ensure you have up-to-date information about available first aid options.

After the initial care of injured people, immediately inform your supervisor of any personal injuries, damage to the machine or material damages.

In the event of the specific use of emergency vehicles, state the severity of the injury and damage.

In a disaster situation, immediately leave the machine (fire).

## **12 Behaviour in dangerous situations**

- If the implement threatens to tip over, lower the load to the ground immediately!
- All cylinders are double-acting so that they stop when the grapple reaches the ground.
- Do not open the grapple claws!
- Do not jump out of the vehicle!
- If the boom system starts to slide downwards in an overload situation, carefully bring the load up to the centre of rotation!
- Do not open the grapple claws!

### Life-saving information for the situation: Crane gets caught in power line

- If you are outside the vehicle, avoid any contact. Do not attempt to enter the vehicle.
- Make sure that no one else tries to get into the vehicle. Stay away from the vehicle!
- If you are in the vehicle, you should move away by jumping with both legs. This should be done at the latest when smoke is visible from the rubber tyres.
- You can also hop away by keeping one leg tucked in and only one foot touching the ground at a time.
- The reason for this method of movement is that the stress field in the ground causes a life-threatening difference in tension between the feet.
- Only when you are about 20 metres away from the machine, you can move further away normally.
- Call for help immediately.

## **Note**

In the pursuit of technical advancement, Binderberger Maschinenbau GmbH continually works to improve its products. We reserve the right to make changes from the illustrations and descriptions in this operating manual/replacement parts list. This cannot give rise to any claim to changes on machines that have been already delivered. The technical data, dimensions and weights are not binding.

Errors excepted.



Händlerstempel:

Typenschild:



Maschinenbau GmbH  
Fillmannsbach 9  
A-5144 St. Georgen am Fillmannsbach  
Tel: +43 / 7748 / 8620  
Fax: +43 / 7748 / 8620 – 20  
office@binderberger.com  
**[www.binderberger.com](http://www.binderberger.com)**