

# Belt conveyor Pro



**Original Operator's Manual** Copyright by Binderberger GmbH



Read the operating instructions carefully before  
commissioning the machine!

**This manual is valid for:**

| <b>Model</b>         | <b>Article number</b> |
|----------------------|-----------------------|
| Conveyor Pro E 4,5 m | FB-MFP-1              |
| Conveyor Pro S 4,5 m | FB-MFP-2              |
| Conveyor Pro E 7,0 m | FB-MFP-3              |
| Conveyor Pro S 7,0 m | FB-MFP-4              |

**Version of this manual:**

**1.0**

**Creation date:**

**2021-05**

## Table of Content

|     |                                                    |    |
|-----|----------------------------------------------------|----|
| 1   | EC Declaration of Conformity .....                 | 4  |
| 2   | Safety instructions .....                          | 5  |
| 2.1 | Explanation of symbols .....                       | 5  |
| 2.2 | General safety instructions .....                  | 6  |
| 2.3 | Intended use .....                                 | 6  |
| 2.4 | Operator requirements.....                         | 6  |
| 2.5 | Modifications to the machine.....                  | 7  |
| 2.6 | Misuse and residual risks .....                    | 7  |
| 3   | Description of the machine.....                    | 8  |
| 3.1 | How it works .....                                 | 8  |
| 3.2 | Overview .....                                     | 9  |
| 3.3 | Technical data .....                               | 9  |
| 4   | Transport of the machine .....                     | 10 |
| 4.1 | Safety instructions during transport.....          | 10 |
| 4.2 | Transport of the belt conveyor .....               | 10 |
| 5   | Set up of the machine .....                        | 11 |
| 5.1 | Safety instructions for set up.....                | 11 |
| 5.2 | Electrical supply line .....                       | 12 |
| 5.3 | Check the direction of rotation of the motor ..... | 12 |
| 5.4 | Connecting the hydraulic hoses.....                | 13 |
| 5.5 | Folding up the belt conveyor .....                 | 13 |
| 6   | Operation .....                                    | 14 |
| 6.1 | Safety instructions during operation .....         | 14 |
| 6.2 | Important instructions during operation.....       | 15 |

- 6.3 Working with the belt conveyor ..... 16
  - 6.3.1 Starting the conveyor belt ..... 16
- 6.4 Swivelling the belt conveyor ..... 17
- 6.5 Daily inspection ..... 17
- 7 Shut down ..... 18
  - 7.1 Safety instructions for decommissioning ..... 18
  - 7.2 Switching off the belt conveyor ..... 19
- 8 Maintenance ..... 20
  - 8.1 Safety instructions during maintenance ..... 20
  - 8.2 Important notes during maintenance ..... 21
  - 8.3 Notes when working on electric equipment ..... 22
  - 8.4 Notes when working on hydraulic equipment ..... 22
  - 8.5 Check the conveyor belt ..... 23
  - 8.6 Cleaning ..... 23
  - 8.7 Tensioning the conveyor belt ..... 23
  - 8.8 Centring the conveyor belt ..... 24
  - 8.9 Changing the hydraulic hoses ..... 24
  - 8.10 Maintenance scheme ..... 24
  - 8.11 Duties before finishing work ..... 25
- 9 Help in case of malfunctions ..... 26
  - 9.1 Safety instructions ..... 26
- 10 Guarantee and Warranty ..... 28
- 11 Conduct when dealing with accidents ..... 29

## 1 EC Declaration of Conformity

We hereby declare that the various technical versions of the machine:

Designation:                      Conveyor Pro \_\_\_\_\_  
Type:                                      FB3 E / FB3 S / FB5 E / FB5 S  
Serial number:                      \_\_\_\_\_

comply with the provisions of the Machinery Directive 2006/42 / EC and the other related standards.

The machine mentioned meets the requirements of the EMC Directive 2004/108 / EC and the Low Voltage Directive 2006/95 / EC.

The accompanying safety regulations and operating instructions apply to these machines.

The machines must not be modified. If changes are made to the machine that have not been agreed with us, this declaration becomes invalid.

The following named place

- has carried out the type examination. The product has received the EC type examination under the number \_\_\_\_\_.
- has carried out the EC type-examination procedure specified in Annex IX of 2006/42 / EC.

*Notified checkplace for type examination according to Annex IX*

The following is the name and address of the person authorized to compile the technical documentation.

CEO Karl Binderberger  
Binderberger Maschinenbau GmbH  
Fillmannsbach 9  
AT-5144 St. Georgen am Fillmannsbach

## 2 Safety instructions

### 2.1 Explanation of symbols

Please pay attention to the meaning of the following symbolic explanations and instructions description. They are divided into levels of risk and classified in accordance with ISO 3864- 2

|                                                                                   |                                                                                                                                                    |
|-----------------------------------------------------------------------------------|----------------------------------------------------------------------------------------------------------------------------------------------------|
| <b>DANGER</b>                                                                     |                                                                                                                                                    |
|  | <i>Indicates an immediate threat of danger.<br/>If the information is not followed, death or serious bodily injury (invalidity) is the result.</i> |

|                                                                                   |                                                                                                                                                        |
|-----------------------------------------------------------------------------------|--------------------------------------------------------------------------------------------------------------------------------------------------------|
| <b>WARNING</b>                                                                    |                                                                                                                                                        |
|  | <i>Indicates a potentially dangerous situation.<br/>If the information is not followed, death or serious bodily injury (disability) are the result</i> |

|                                                                                     |                                                                                                                                                                        |
|-------------------------------------------------------------------------------------|------------------------------------------------------------------------------------------------------------------------------------------------------------------------|
| <b>CAUTION</b>                                                                      |                                                                                                                                                                        |
|  | <i>Indicates a potentially dangerous situation. If the information is not followed, material damage as well as minor or moderate physical injuries are the result.</i> |

|                                                                                     |                                                                                                                                                               |
|-------------------------------------------------------------------------------------|---------------------------------------------------------------------------------------------------------------------------------------------------------------|
| <b>NOTICE</b>                                                                       |                                                                                                                                                               |
|  | <i>Indicates general instructions, useful operator instructions and working recommendations that have no influence on the safety and health of personnel.</i> |

## 2.2 General safety instructions

The machine may only be operated by people who are trained, instructed and authorised for its use. These people must know the operating instructions and act in accordance with them. The respective competences of the operating personnel are clearly defined.

Operating personnel undergoing training may only initially work with the machine under the supervision of an experienced person. The completed and successful instruction is to be confirmed in writing

## 2.3 Intended use

The conveyor is designed exclusively for conveying logs and firewood. All other forms of usage do not comply with the intended use. The manufacturer is not responsible for any personal injury or material damage that originates from non-compliant usage, but rather the operator of the machine is!

The reading of this manual as well as the observance of all instructions contained within it, particularly the safety instructions, also comply with the intended use. Also included is the fact that all inspection and servicing work is to be conducted in the prescribed time intervals.

## 2.4 Operator requirements

No special knowledge of mechanical or electrical engineering is required to operate the machine. However, the operator must be at least **18 years** old. The operator must be trained and instructed accordingly by the operator of the machine before starting work for the first time (see General safety regulations). Protective shoes and close-fitting clothing must be worn when operating the machine.

If the operator carries out maintenance and servicing work, he must have the necessary specialist knowledge.

## 2.5 Modifications to the machine

For safety reasons, no unauthorised modifications may be made to the machine; this applies in particular to welding work on load-bearing parts.

Only use original spare parts / original wear parts / original accessories - these parts are specially designed for the machine. In the case of externally sourced parts, there is no guarantee that they are designed and manufactured to withstand stress and safety.

Parts and special equipment not supplied by us are also not approved by us for use on the machine.

## 2.6 Misuse and residual risks

Despite correct application of all safety instructions for the machine, residual risks can still occur. These usually result from misuse of the machine.

- Touching rotating or moving components
- Injury from falling wooden or machine parts.
- Fire hazard due to inadequate ventilation of the engine
- Hearing damage from working without hearing protection
- Human error:
  - Mental overload
  - Excessive physical exertion
  - Entering a danger zone
  - Distractions
  - Neglected control activities



### 3 Description of the machine

#### 3.1 How it works

The conveyor is driven either by an electric motor (400V/16A) or by an oil motor directly on the drive shaft.

The conveyor belt can also be folded in the middle. This means that it requires less storage space.

The conveyor belt may only be used, serviced or maintained by persons who are familiar with it and have been informed about the dangers.

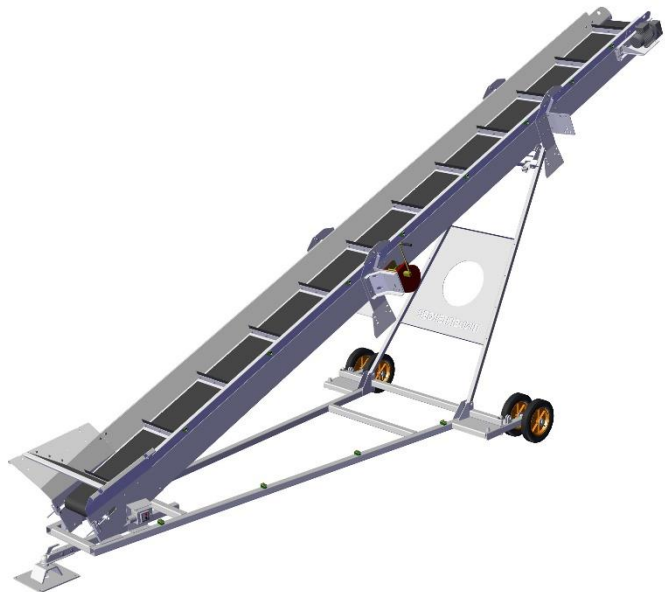

### 3.2 Overview

**Conveyor 4,5m**

**Conveyor 7m**

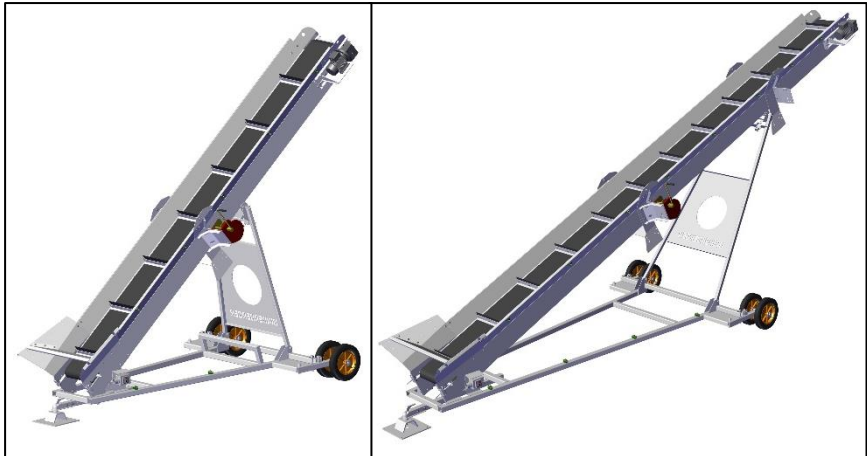

### 3.3 Technical data

| Type                      | FB Pro E<br>4,5m | FB Pro S<br>4,5m | FB Pro E<br>7,0m | FB Pro S<br>7,0m |
|---------------------------|------------------|------------------|------------------|------------------|
| <b>Belt width [cm]</b>    | 40 cm            | 40 cm            | 40 cm            | 40 cm            |
| <b>Belt length [cm]</b>   | 450 cm           | 450 cm           | 700 cm           | 700 cm           |
| <b>Drive</b>              | Electro          | Tractor          | Electro          | Tractor          |
| <b>E-motor power [kW]</b> | 0,75 kW          | -                | 0,75 kW          | -                |
| <b>Weight [kg]*</b>       | 720 kg           | 720 kg           | 800 kg           | 800 kg           |

\*...the dimensions and weights given are approximate values

## 4 Transport of the machine

### 4.1 Safety instructions during transport

| <b>WARNING</b>                                                                    |                                                                                                                                                                                                                                                                                                                                                                                                                                                                                                                                                                                    |
|-----------------------------------------------------------------------------------|------------------------------------------------------------------------------------------------------------------------------------------------------------------------------------------------------------------------------------------------------------------------------------------------------------------------------------------------------------------------------------------------------------------------------------------------------------------------------------------------------------------------------------------------------------------------------------|
|  | <p style="text-align: center;"><b><u>Risk of injury during transport!</u></b></p> <ul style="list-style-type: none"><li>• Make sure that there are no persons in the danger zone and that a sufficient safety distance is kept!</li><li>• The machine may only be lifted at the designated holding points!</li><li>• The specified position for transporting the machine must be strictly adhered to</li><li>• Protruding sharp edges can cause cut injuries.</li><li>• Suspended loads can fall down, then there is danger to life - do not stay under suspended loads!</li></ul> |

### 4.2 Transport of the belt conveyor

The belt conveyor can be positioned in the working position, i.e., in the unfolded state. However, it is not permitted to transport the belt conveyor over a longer distance in this position. For transport, the belt conveyor must be folded out and placed in the transport position. **See 5.6 Unfolding the belt conveyor.**

It is advantageous to store the belt conveyor on a wooden pallet to facilitate transport.

**CAUTION:** Do not use damaged chain slings or belts.

**Pulling the machine in road traffic is not permitted under any circumstances!**

## 5 Set up of the machine

### 5.1 Safety instructions for set up

| <h1 style="margin: 0;">WARNING</h1>                                               |                                                                                                                                                                                                                                                                                                                                                                                                                                                                                                                                                                                                                                                                                                                                                                                                                                                                                                                                                                                                                                                             |
|-----------------------------------------------------------------------------------|-------------------------------------------------------------------------------------------------------------------------------------------------------------------------------------------------------------------------------------------------------------------------------------------------------------------------------------------------------------------------------------------------------------------------------------------------------------------------------------------------------------------------------------------------------------------------------------------------------------------------------------------------------------------------------------------------------------------------------------------------------------------------------------------------------------------------------------------------------------------------------------------------------------------------------------------------------------------------------------------------------------------------------------------------------------|
|  | <p><b><u>Risk of injury if the machine is not set up correctly!</u></b></p> <ul style="list-style-type: none"><li>• Always check the machine for transport damage before setting it up!</li><li>• Set up the machine on a level and firm surface!</li><li>• Use the support feet of the machine!</li><li>• Ensure that no persons are endangered by the installation!</li><li>• Lay machine connections, cables and hoses in such a way that there are no tripping hazards!</li><li>• Incorrectly laid or improperly fastened machine parts can fall or topple over.</li><li>• Live cable ends and components can cause injuries due to electric current.</li><li>• The machine may only be operated when in perfect condition!</li><li>• Do not attach or detach pressurised hoses!</li><li>• Hoses under pressure must not be routed into the driver's cab! If this is not possible, it must be ensured that the operator cannot be injured if the hose bursts!</li><li>• Ensure that there are no persons between the machine and the tractor!</li></ul> |

## 5.2 Electrical supply line

The fuse and dimensioning of the electrical supply line must be selected by a qualified electrician in accordance with national standards and depending on the length of the line!

Connect the 5-pole CEE 400V/16A supply cable to the plug.

**Never carry out work on electrical equipment if you do not have the necessary expertise!**

## 5.3 Check the direction of rotation of the motor

(Electric drive only)

If your belt conveyor turns in the wrong direction, this is usually due to the electric motor.

If this is the case, the fan blade on the motor rotates against the sticker on it.

If the direction of rotation is not correct, disconnect the supply cable to the belt conveyor.

There is a phase inverter in the plug with which you can change the direction of rotation of the motor (press the disc in the plug in with a screwdriver and turn it 180°).



## 5.4 Connecting the hydraulic hoses (tractor hydraulics)

Connect the hydraulic hoses of the belt conveyor to a double-acting control unit of a tractor or to a hydraulic power pack.

## 5.5 Folding up the belt conveyor

To bring the belt conveyor into working position it is necessary to fold back the upper part and bring it in line with the lower part of the belt conveyor. Both conveyor halves must be firmly connected in the middle with 4 screws. The belt conveyor can then be adjusted to the desired height.

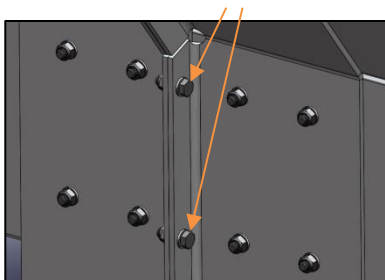

## 6 Operation

### 6.1 Safety instructions during operation

| <b>DANGER</b>                                                                     |                                                                                                                                                                                                                                                                                                                                                                                               |
|-----------------------------------------------------------------------------------|-----------------------------------------------------------------------------------------------------------------------------------------------------------------------------------------------------------------------------------------------------------------------------------------------------------------------------------------------------------------------------------------------|
|  | <p><b><u>Risk of injury from being caught or pulled in on moving machine parts!</u></b></p> <ul style="list-style-type: none"><li>• Keep a sufficient safety distance from moving machine parts!</li><li>• Do not stand under the belt conveyor, it may fall down!</li><li>• No persons are allowed to be within a radius of at least 4m in the area of the belt conveyor ejection.</li></ul> |

| <b>WARNING</b>                                                                      |                                                                                                                                                                                                                                                                                                                                                                                                                                                                                                                  |
|-------------------------------------------------------------------------------------|------------------------------------------------------------------------------------------------------------------------------------------------------------------------------------------------------------------------------------------------------------------------------------------------------------------------------------------------------------------------------------------------------------------------------------------------------------------------------------------------------------------|
|  | <p><b><u>Risk of injury when operating!</u></b></p> <ul style="list-style-type: none"><li>• Make sure that there are no persons in the danger zone and that a sufficient safety distance is maintained!</li><li>• Familiarise yourself with the controls of the circular saw!</li><li>• Ensure that the machine is standing securely!</li><li>• Remove all parts that do not belong to the machine from its vicinity. (tripping)</li><li>• Wear protective gloves and safety shoes with steel toecaps.</li></ul> |

## 6.2 Important instructions during operation

| <h1>NOTICE</h1>                                                                   |                                                                                                                                                                                                                                                                                                                                                                                                                                                                                                  |
|-----------------------------------------------------------------------------------|--------------------------------------------------------------------------------------------------------------------------------------------------------------------------------------------------------------------------------------------------------------------------------------------------------------------------------------------------------------------------------------------------------------------------------------------------------------------------------------------------|
|  | <ul style="list-style-type: none"><li>• Make sure that your workplace is sufficiently illuminated.</li><li>• Before switching on the machine, inform yourself about the correct behaviour in case of malfunctions.</li><li>• After switching off the machine, always carry out the steps described in the following chapter "Decommissioning".</li><li>• If the operating personnel leave the machine unattended, it must be switched off and secured against unauthorised restarting.</li></ul> |

### Operation under power lines:

Pay strict attention to the safety distance when working under power lines. No part of the machine may come closer than the specified safety distances:

For low-voltage lines: min. 2 metres  
For high-voltage lines: min. 6 metres

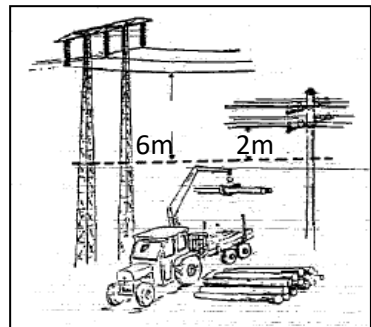



### 6.3 Working with the belt conveyor

After you have carried out all the points from the chapter "Set up of the machine", you can start working.

#### 6.3.1 Starting the conveyor belt

##### Electric drive

To start the belt conveyor with electric motor, the switch is located on the left side.



This has 2 buttons, the green button for switching the machine on and the red button for switching it off.

Before starting, however, the direction of rotation check (chapter 5.4) should be carried out.

##### Tractor drive

To start the belt conveyor with tractor drive, simply connect it to the double-acting control unit with latching position of the tractor.

The belt conveyor can then be started with the control unit, again making sure that the belt rotates in the correct direction.

## 6.4 Swivelling the belt conveyor

To swivel the belt conveyor, remove the locking bolts on the axles. Move the belt conveyor to the left and right so that the axles align correctly. Now lock the axles again. Now you can swivel the belt conveyor.

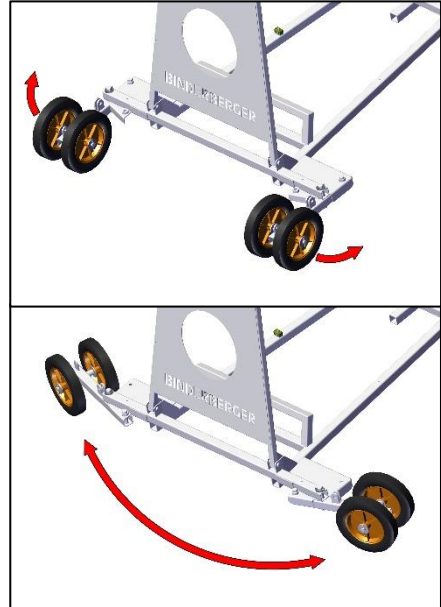

## 6.5 Daily inspection

Visually inspect the unit. Look for faults and defects that could have an influence on safety. Any faults and defects must be rectified.

- Make sure that there are no leaks in the hydraulics.
- Make sure that there are no damaged hoses or cables.

## 7 Shut down

### 7.1 Safety instructions for decommissioning

| <b>DANGER</b>                                                                     |                                                                                                                                                                                                                                                                                                    |
|-----------------------------------------------------------------------------------|----------------------------------------------------------------------------------------------------------------------------------------------------------------------------------------------------------------------------------------------------------------------------------------------------|
|  | <p><b><u>Risk of injury from being caught or pulled in on moving machine parts!</u></b></p> <ul style="list-style-type: none"><li>• After parking, wait until all moving machine parts have come to a standstill!</li><li>• Keep a sufficient safety distance from moving machine parts!</li></ul> |

| <b>WARNING</b>                                                                     |                                                                                                                                                                                                                                                                                                                                                                     |
|------------------------------------------------------------------------------------|---------------------------------------------------------------------------------------------------------------------------------------------------------------------------------------------------------------------------------------------------------------------------------------------------------------------------------------------------------------------|
|  | <p><b><u>Risk of injury when shutting down</u></b></p> <ul style="list-style-type: none"><li>• Make sure that there are no persons in the danger zone and that a sufficient safety distance is kept!</li><li>• Do not stand under suspended loads, they may fall down!</li><li>• Make sure that there are no persons between the machine and the tractor!</li></ul> |

| <b>WARNING</b>                                                                    |                                                                                                                                                                                                                                                                                                                                  |
|-----------------------------------------------------------------------------------|----------------------------------------------------------------------------------------------------------------------------------------------------------------------------------------------------------------------------------------------------------------------------------------------------------------------------------|
|  | <p><b><u>Risk of injury when switching on the machine by unauthorised persons!</u></b></p> <ul style="list-style-type: none"><li>• Secure the machine after operation against unauthorised switching on!</li><li>• When leaving the workplace of the machine for a longer period of time, disconnect the power source.</li></ul> |

## **7.2 Switching off the belt conveyor**

When you have finished working, wait until the last material has been transported off the belt conveyor and the belt conveyor is empty.

Now switch off the respective drive and wait until the belt conveyor comes to a standstill.

Now disconnect the respective power source from the belt conveyor.

If the machine is not expected to be used for a longer period of time or if you leave the working area, secure the belt conveyor against unauthorised switching on.

## 8 Maintenance

### 8.1 Safety instructions during maintenance

| <b>DANGER</b>                                                                     |                                                                                                                                                                                                                                                                     |
|-----------------------------------------------------------------------------------|---------------------------------------------------------------------------------------------------------------------------------------------------------------------------------------------------------------------------------------------------------------------|
|  | <p><b><u>Serious risk of injury from switching on the drive during maintenance work!</u></b></p> <ul style="list-style-type: none"><li>• Switch off the machine!</li><li>• Secure against being switched on again!</li><li>• Disconnect from power source</li></ul> |

| <b>CAUTION</b>                                                                    |                                                                                                                                                                                                                                                                                                                                                                                                                                                 |
|-----------------------------------------------------------------------------------|-------------------------------------------------------------------------------------------------------------------------------------------------------------------------------------------------------------------------------------------------------------------------------------------------------------------------------------------------------------------------------------------------------------------------------------------------|
|  | <p><b><u>Caution: Lubricant!</u></b></p> <ul style="list-style-type: none"><li>• Use suitable collection containers.</li><li>• Remove spilled oil immediately.</li><li>• Avoid contact with skin and eyes.</li><li>• Do not swallow or inhale.</li><li>• Use suitable protective equipment (gloves, goggles).</li><li>• Take care that no oil gets into the environment.</li><li>• Spilled oil pollutes water bodies and groundwater.</li></ul> |

| <b>CAUTION</b>                                                                      |                                                                                                                                                                                                                                                                                                       |
|-------------------------------------------------------------------------------------|-------------------------------------------------------------------------------------------------------------------------------------------------------------------------------------------------------------------------------------------------------------------------------------------------------|
|  | <p><b><u>Risk of injury! Scalding by hot machine components and media!</u></b></p> <ul style="list-style-type: none"><li>• Allow the machine to cool down to ambient temperature before carrying out any maintenance work.</li><li>• Keep highly flammable material away from hot surfaces.</li></ul> |

## 8.2 Important notes during maintenance

| <h1>NOTICE</h1>                                                                   |                                                                                                                                                                                                                                                                                                                                                                                                                                                                                                                                                                                                                                                                                                                                                                                                                                                                                                                                                                                                                                                                                                                                                                                                                                                                                                                                                                                                                                                                               |
|-----------------------------------------------------------------------------------|-------------------------------------------------------------------------------------------------------------------------------------------------------------------------------------------------------------------------------------------------------------------------------------------------------------------------------------------------------------------------------------------------------------------------------------------------------------------------------------------------------------------------------------------------------------------------------------------------------------------------------------------------------------------------------------------------------------------------------------------------------------------------------------------------------------------------------------------------------------------------------------------------------------------------------------------------------------------------------------------------------------------------------------------------------------------------------------------------------------------------------------------------------------------------------------------------------------------------------------------------------------------------------------------------------------------------------------------------------------------------------------------------------------------------------------------------------------------------------|
|  | <ul style="list-style-type: none"><li>• Depressurise all pressure units</li><li>• The prescribed maintenance work - adjustment, cleaning, maintenance, inspection, ... must be carried out in due time</li><li>• All maintenance steps must be carried out in the specified order.</li><li>• Immediately replace all machine parts that are not in perfect condition.</li><li>• Use only original spare parts.</li><li>• Ensure that suitable collection containers are available for all substances hazardous to groundwater (oils, coolants, etc.).</li><li>• Self-locking screws and nuts must always be renewed.</li><li>• All operating materials and lubricants that are not reused must be disposed of in an environmentally friendly manner.</li><li>• There is a risk of fire during welding work. Have fire extinguishers ready.</li><li>• Ensure that adequate lifting equipment and load lifting devices are available for the replacement of larger machine parts.</li><li>• Never release the machine for operation without the factory provided safety devices.</li><li>• It is strictly forbidden to remove safety notices affixed to the machine.</li><li>• Replace the information stickers on the machine if they are no longer legible.</li><li>• Do not carry out repairs if you do not have the required qualifications.</li><li>• Always ensure that the prescribed operating materials are present in the machine in sufficient quantities.</li></ul> |

### **8.3 Notes when working on electric equipment**

All work on the electrical equipment of the machine may only be carried out by trained electricians. Check electrical equipment regularly:

- Reattach loose connections.
- Replace damaged lines or cables immediately.

Whenever work is carried out on live machine parts or cables, a second person must always be present to disconnect the power supply in an emergency. Never clean electrical equipment with water or similar liquids.

### **8.4 Notes when working on hydraulic equipment**

All work on the hydraulic equipment of the machine may only be carried out by trained specialists.

Depressurise all hydraulic systems and parts before starting work. Before starting work, ensure that suitable collection containers are available for all substances hazardous to groundwater (oils, coolants, etc.).

### 8.5 Check the conveyor belt

After each operation, the rubber mats must be checked for damage and replaced if necessary.

### 8.6 Cleaning

After each operation and before each maintenance, the machine must be cleaned of dirt!

After each cleaning with water, the log splitter must be lubricated!

### 8.7 Tensioning the conveyor belt

The conveyor belt must be retightened regularly. To do this, first loosen the 4 screws (1). Then the upper pulley can be moved using the two threaded rods (2).

Always make sure that the belt is tensioned equally on both sides. Otherwise, the belt conveyor would no longer run centrally.

After tensioning, tighten the fixing screws (1) again to prevent automatic loosening.

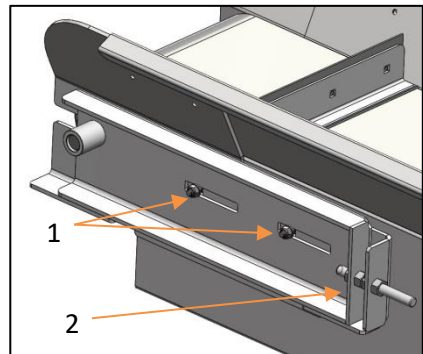



### 8.8 Centring the conveyor belt

If the belt conveyor is loose or runs to one side, you can adjust it using the adjusting screws at the top and bottom of the belt conveyor.

At the top, this is done by tightening or loosening the belt conveyor on one side.

At the bottom, the entire drive roller can be swivelled by means of the threaded rod.

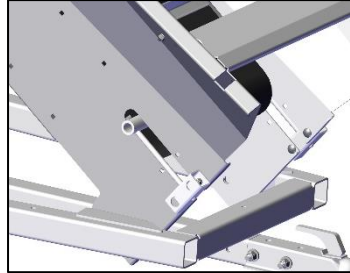

### 8.9 Changing the hydraulic hoses

All hydraulic hoses must be replaced after 5 years.

Otherwise, damage to the hoses can cause serious injuries.

### 8.10 Maintenance scheme

Regular maintenance is the best guarantee that your machine will work effectively and economically. The belt conveyor has already been carefully tested and adjusted at the factory.

### **8.11 Duties before finishing work**

After completing the maintenance work and before starting the machine, observe the following points:

- Check all previously loosened screw connections for tightness.
- Check that all previously removed guards, covers, container lids, .... are properly reinstalled.
- Make sure that all tools, materials and other equipment used have been removed from the work area.
- Cleaning the work area
- Ensure that all safety devices of the machine are working properly again.
- Check the function of the safety devices. Do not release the machine for use if the safety devices are not functioning properly.
- Carry out a test run with a function check of the repaired components.
- Secure the machine against unauthorised switching on if you have not completed the work.
- Do not handle naked flames or smoke.

## 9 Help in case of malfunctions

### 9.1 Safety instructions

| <b>DANGER</b>                                                                     |                                                                                                                                                                                                                                                                               |
|-----------------------------------------------------------------------------------|-------------------------------------------------------------------------------------------------------------------------------------------------------------------------------------------------------------------------------------------------------------------------------|
|  | <p><b><u>Serious risk of injury from switching on the drive in the event of a malfunction!</u></b></p> <ul style="list-style-type: none"><li>• Switch off the machine!</li><li>• Secure against being switched on again!</li><li>• Disconnect from the power supply</li></ul> |

| <b>CAUTION</b>                                                                    |                                                                                                                                                                                                                                     |
|-----------------------------------------------------------------------------------|-------------------------------------------------------------------------------------------------------------------------------------------------------------------------------------------------------------------------------------|
|  | <p><b><u>Risk of injury! Scalding by hot machine components and media!</u></b></p> <ul style="list-style-type: none"><li>• Allow the machine to cool down to ambient temperature before carrying out any troubleshooting.</li></ul> |

| <b>CAUTION</b>                                                                      |                                                                                                                                                           |
|-------------------------------------------------------------------------------------|-----------------------------------------------------------------------------------------------------------------------------------------------------------|
|  | <p><b><u>Crushing hazard</u></b></p> <ul style="list-style-type: none"><li>• <i>There is a crushing hazard at various points on the machine</i></li></ul> |

| <h2 style="text-align: center; margin: 0;">CAUTION</h2>                           |                                                                                                                                                                                                                                                       |
|-----------------------------------------------------------------------------------|-------------------------------------------------------------------------------------------------------------------------------------------------------------------------------------------------------------------------------------------------------|
|  | <p><b><u>Danger of burns due to contact with lubricants!</u></b></p> <ul style="list-style-type: none"><li>• Avoid skin and eye contact.</li><li>• Do not swallow or inhale.</li><li>• Use suitable protective equipment (gloves, goggles).</li></ul> |

| <h2 style="text-align: center; margin: 0;">NOTICE</h2>                            |                                                                                                                                                                                                                                                                                                    |
|-----------------------------------------------------------------------------------|----------------------------------------------------------------------------------------------------------------------------------------------------------------------------------------------------------------------------------------------------------------------------------------------------|
|  | <ul style="list-style-type: none"><li>• All work on the electrical equipment of the machine may only be carried out by trained electricians.</li><li>• Only rectify a fault if you also have the specified qualification.</li><li>• Also read the chapter "General safety instructions".</li></ul> |

If faults cannot be eliminated, please contact your specialist dealer! He will be happy to help you.

## **10 Guarantee and Warranty**

### **Guarantee Terms 950601:**

The Binderberger Maschinenbau GmbH company provides a guarantee for a period of two years on parts that fail to fulfil their intended purpose as the result of material defects or production errors.

A one-year guarantee is provided by our suppliers on goods procured by us, such as wheels, pumps and valves. The guarantee comes into force with the delivery date.

The guarantee does not cover failures that are due to normal wear, inattentiveness, incorrect use and incorrect assembly. Hydraulic hoses and couplings are excluded from the guarantee.

Costs that originate within the scope of the guarantee procedure for detaching, assembly and delivery are not refunded. The fault should be repaired upon the mutual arrangement of the customer, the appointed dealer and the Binderberger company. The fault should be repaired following a mutual arrangement between the customer, the appointed dealer and the Binderberger company.

For this, the model of the machine, the production number, the delivery date and the name of the owner, as well as the address, must be indicated. For this, the model of the machine, the production number, the delivery date and the name of the owner as well as the address must be presented.

The guarantee is invalid if the machine deviates from the original implementation, e.g., due to changes, set-up, additional constructions or the replacement of parts that have not been delivered by us. Otherwise, the NL92 delivery regulations are valid.

## **11 Conduct when dealing with accidents**

Routinely find out at regular intervals what first aid facilities are available.  
Inform your supervisor immediately - after the initial treatment of injured persons - in the event of accidents involving personal injury, damage to equipment or damage to buildings.

State the severity of personal injury and property damage for the targeted deployment of rescue vehicles.

In the event of a disaster (fire, ...), leave the machine immediately.

## Notes

---

---

---

---

---

---

---

---

---

---

---

---

---

---

---

---

---

---

---

---

---

---

---

---

### **Note**

In the pursuit of technical advancement, Binderberger Maschinenbau GmbH continually works to improve its products. We reserve the right to make changes from the illustrations and descriptions in this operating manual/replacement parts list. This cannot give rise to any claim to changes on machines that have been already delivered. The technical data, dimensions and weights are not binding.

Errors excepted.

Dealer's stamp:

Name plate:



Maschinenbau GmbH  
Fillmannsbach 9  
A-5144 St. Georgen am Fillmannsbach  
Phone: +43 / 7748 / 8620  
Fax: +43 / 7748 / 8620 – 20  
office@binderberger.com  
**[www.binderberger.com](http://www.binderberger.com)**